



**CHC Series**  
High Capacity Refrigerated Dryer  
2,000–20,000 SCFM

**NEW**



Engineered to Save

# CHC Series

## ⇒ Custom Designed to Meet Your Needs

- Engineered to economically produce consistent dew points with low pressure drops.
- In-house design allows precision computer matching of air sides and refrigeration systems to your flow, dew point, and pressure drop requirements.
- Several sizings can be computed so that you can evaluate initial costs versus various pressure drop and dew point options.

Input Data	
Flow rate:	<input type="text"/>
Compressed air conditions	
Inlet temperature:	<input type="text"/>
Inlet pressure:	<input type="text"/>
Required outlet dewpoint:	<input type="text"/>
Required pressure drop across dryer:	<input type="text"/>
Condenser Cooling Medium:	
Liquid cooled	
Medium ( water, glycol):	<input type="text"/>
Temperature:	<input type="text"/>
Air-Cooled	
Min/Max Ambient	<input type="text"/>
Air Temperature:	<input type="text"/> / <input type="text"/>
Power requirements:	<input type="text"/> V <input type="text"/> ph <input type="text"/> Hz
Gas to be dried:	
Compressed air,	<input type="text"/>
Other (specify)	<input type="text"/>
Output data	
Dryer Model:	<input type="text"/>
Capacity @ conditions indicated:	<input type="text"/>
Outlet dewpoint:	<input type="text"/>
Pressure drop:	<input type="text"/>

Give us the operating conditions (Input Data) listed here and allow us to select a heat exchanger set and condensing unit combination that will most efficiently produce the outlet dewpoint and pressure drop you require.

## ⇒ Low Pressure Drops Save You Money

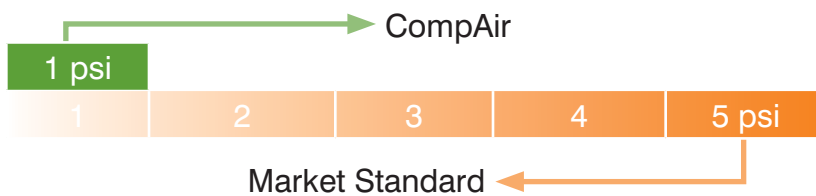

- Pressure Drop: 1 psi (.07 bar) vs. 5 psi (0.34 bar)
- Cost are calculated assuming 24/7 usage at \$0.07 kw-hr and based on the following dryer inlet conditions: 50000 scfm, 100 psig, 100°F inlet, 100°F ambient (8500 m<sup>3</sup>/hr, 7 bar, 38°C inlet, 38°C ambient)

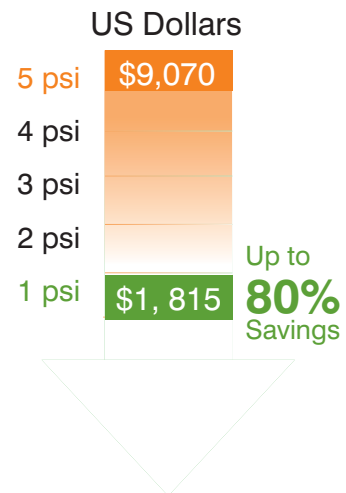

# Features

## ⇒ *Ease of Installation*

- Delivered fully assembled, with all necessary electrical and refrigeration system wiring, piping components and controls installed
- Air, cooling water and drain connections are conveniently located and easily accessible

## ⇒ *Serviceability*

- Refrigerant sight glasses with moisture indicators allow for monitoring of refrigerant quality
- Refrigerant control valves can be repaired without removing valve bodies from the system
- High and low side service valves and isolation valves standard
- Oil sight glass standard

## ⇒ *Electrical Construction*

- Full voltage, magnetic motor starter standard
- All electrical components are UL and CSA approved
- All wires are numbered and enclosed in wire trays

## ⇒ *Fully Insulated Heat Exchangers/Separator/Air Piping Surfaces*

- Preserves cooling effect
- Prevents re-evaporation of liquid within the separator
- Prevents sweating on cold services

## ⇒ *NEMA 4 Rating*

- Water-cooled models: NEMA 4
- Air-cooled models: Dryer and Condenser NEMA 4

## ⇒ *ASME coded and stamped*



# Innovative Technology

## ⇒ Heat Exchangers

- Air-to-air and air-to-refrigerant heat exchangers are highly engineered and encompass a manufactured shell and radial finned tube
- Design ensures sufficient cooling and minimizes pressure drop. Wide tube spacing, baffling, and right angle flow pattern design allows the heat exchangers to resist fouling, adding years of useful service life.

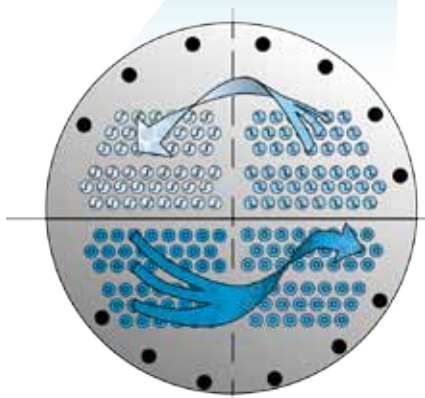
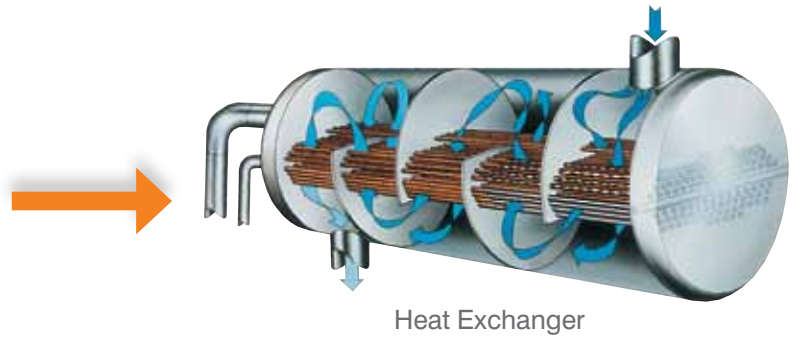

Four Pass System

## ⇒ Air-to-Air Heat Exchangers

- Precools/reheats
- Large heat exchanger removes over half of the heat load from incoming air stream
- Minimizes refrigeration system size and power requirements
- Balances high heat transfer coefficient inside the tubes with the greater surface area on the outside of the tubes
- High heat transfer rate

## ⇒ Air-to-Refrigerant Heat Exchangers

- Large service area permits compressed air stream to be consistently cooled to the dew point temperature
- Four pass refrigerant design allows maximum use of available refrigeration capacity
- Fast response to changes in load

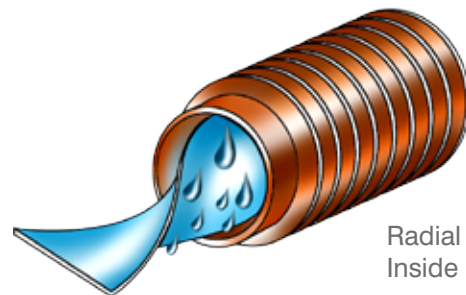

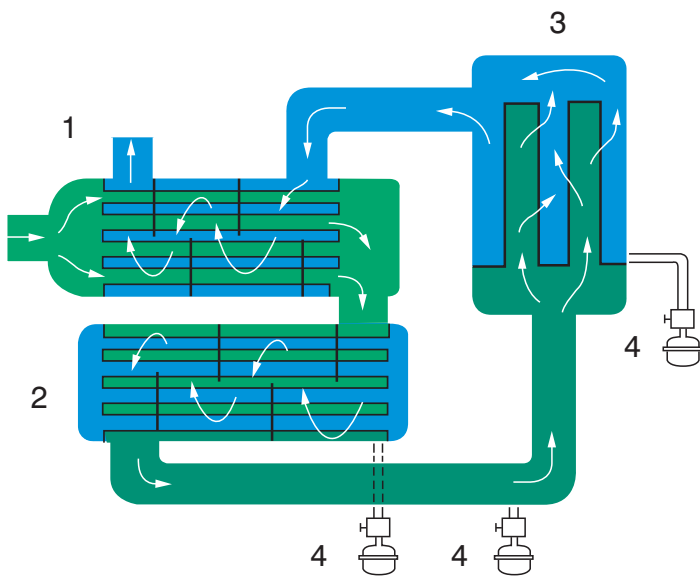

### ⇒ Heat Exchanger Operation

1. Compressed air, saturated with water vapor enters the air-to-air heat exchanger (precooler/reheater) (1) and is precooled by the chilled outgoing air.
2. The precooled air then enters the air-to-refrigerant heat exchanger (2) where it is further cooled by the refrigeration system. As the air cools, water vapor condenses into liquid droplets
3. The air and entrained water droplets then enter the separator (3) where the water droplets are removed from the air stream.
4. Automatic condensate drains (4) discharge the collected water from the system after each heat exchanger and at the separator.
5. The dry, chilled air then passes through the secondary side of the air-to-air heat exchanger (1) where it is reheated as it exits the dryer.

### ⇒ Two Stage Separator

Two stage separator removes 99+% of condensed moisture. This high efficiency is maintained across a wide range of flows and load conditions.

- Stainless steel mechanical separator removes large liquid loads
- Grade B Coalescing filter removes remaining particulates up to 3 micron and oil aerosols to 5 ppm w/w

### ⇒ Automatic Condensate Drains

- Three drains reliably remove condensed moisture from the dryer
- Furnished with isolation valves and piped to a common discharge point
- Pneumatically operated drains are standard through models CHC-0088
- Electrically operated timed drains are standard on models CHC-099 and larger

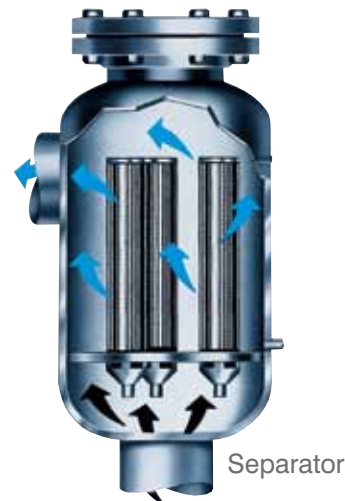

# Refrigeration System



Refrigeration System



## ➔ *Years of Reliability*

- Sized for the heat removal capacity required
- Pressure lubricated
- Operating noise level below 85 dBA at three feet
- Built to maximize integrity by ensuring complete system dryness

## ➔ *Automatic Temperature Control*

- Maintains consistent dewpoint temperature across a wide range of operating conditions
- Designed to produce ample cooling capacity, accurate temperature control and system reliability

## ➔ *Direct Expansion, Non-Cycling Refrigeration*

- Allows rapid response to changes in load

## ➔ *Utilizes the Pump-Down System*

- Pumps refrigerant out of the evaporator for storage in the receiver

## ➔ *Floodback Prevention*

- Ensures excessive liquid refrigerant does not return to compressor during operation

## Three Valve Control System

The CHC Series incorporates a three valve refrigerant control system to control both system pressures and temperatures. The three valve system is superior to the competitors' valve system because it introduces hot gas into the suction line *after* the evaporator to maintain consistent cooling temperature during load changes.

### ⇒ Thermal Expansion Valve (TXV) (1)

- Quickly responds to changes in load
- Controls temperature of refrigerant leaving evaporator
- Prevents excessive liquid from returning to compressor

### ⇒ Highly Accurate, Pilot Operated Hot Gas Bypass Valve (HGBP) (2)

- Maintains constant evaporator pressure
- Hot gas is fed into suction line *AFTER* the evaporator to maintain consistent cooling temperature during load changes
- Prevents TXV from overcompensating

### ⇒ De-Superheating Valve (3)

- Controls temperature of refrigerant gas returning to compressor
- Prevents overheating

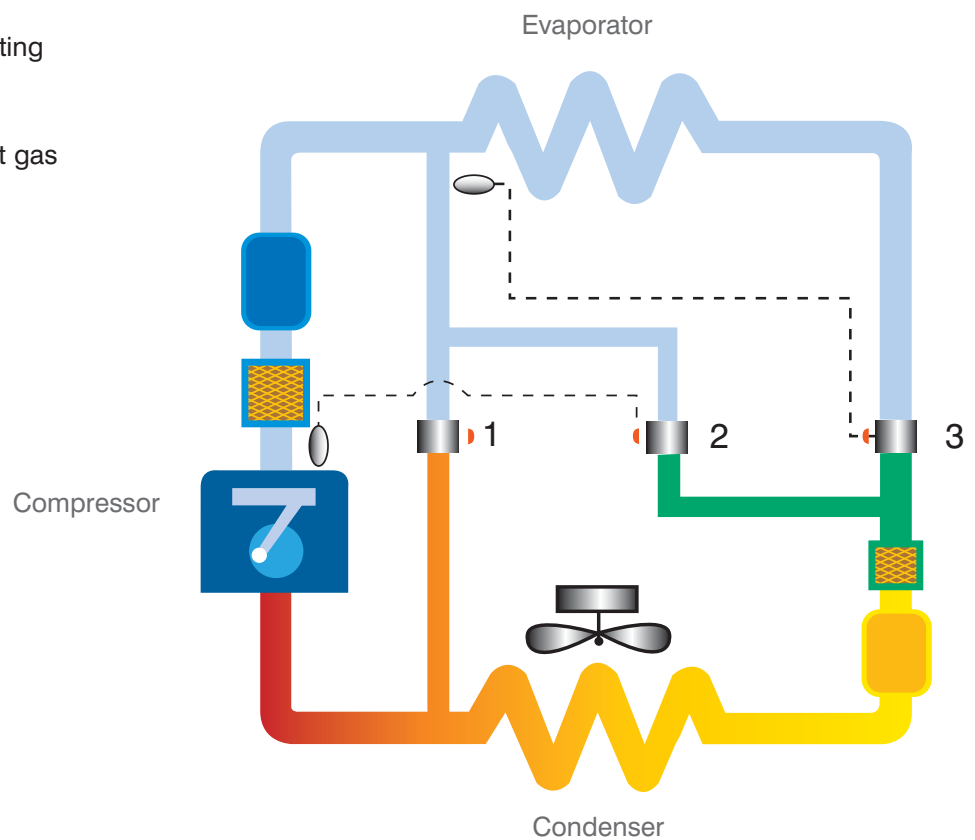

# Refrigeration System

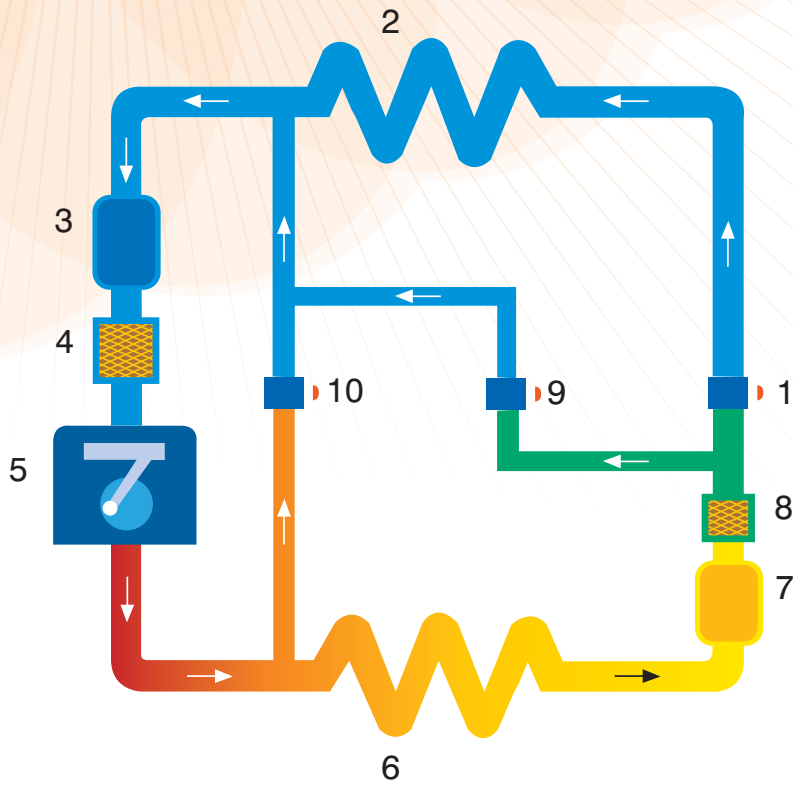

## ➤ Refrigeration System Operation

1. High pressure liquid refrigerant is metered into the air-to-refrigerant heat exchanger (refrigeration system evaporator) (2) through the thermal expansion valve (1) where it becomes a gas.
2. The low pressure gas then moves through the accumulator (3) and the suction line filter (4) to the refrigeration compressor (5) where it is compressed into a high pressure gas.
3. The high pressure gas moves to an air or water cooled condenser (6) where it gives up heat and condenses into a high pressure liquid. The high pressure liquid travels through the receiver (7) and dryer/filter (8) to the thermal expansion valve (1)
4. A hot gas by-pass valve(10) controls evaporator (2) pressure while a desuperheating valve (9) controls the return gas temperature.



# Programmable Controllers

## ➤ Programmable Logic Controller (Standard)

- Monitors oil and refrigerant head and suction pressures and shuts off compressor if fault conditions occur
- Backlit LCD display indicates dryer and compressor operating status, inlet air pressure, refrigerant suction pressure and compressor loading
- Fault message indicators for:
  - » High or low refrigerant pressure
  - » Low oil pressure
  - » Motor starter open
  - » High evaporator temperature

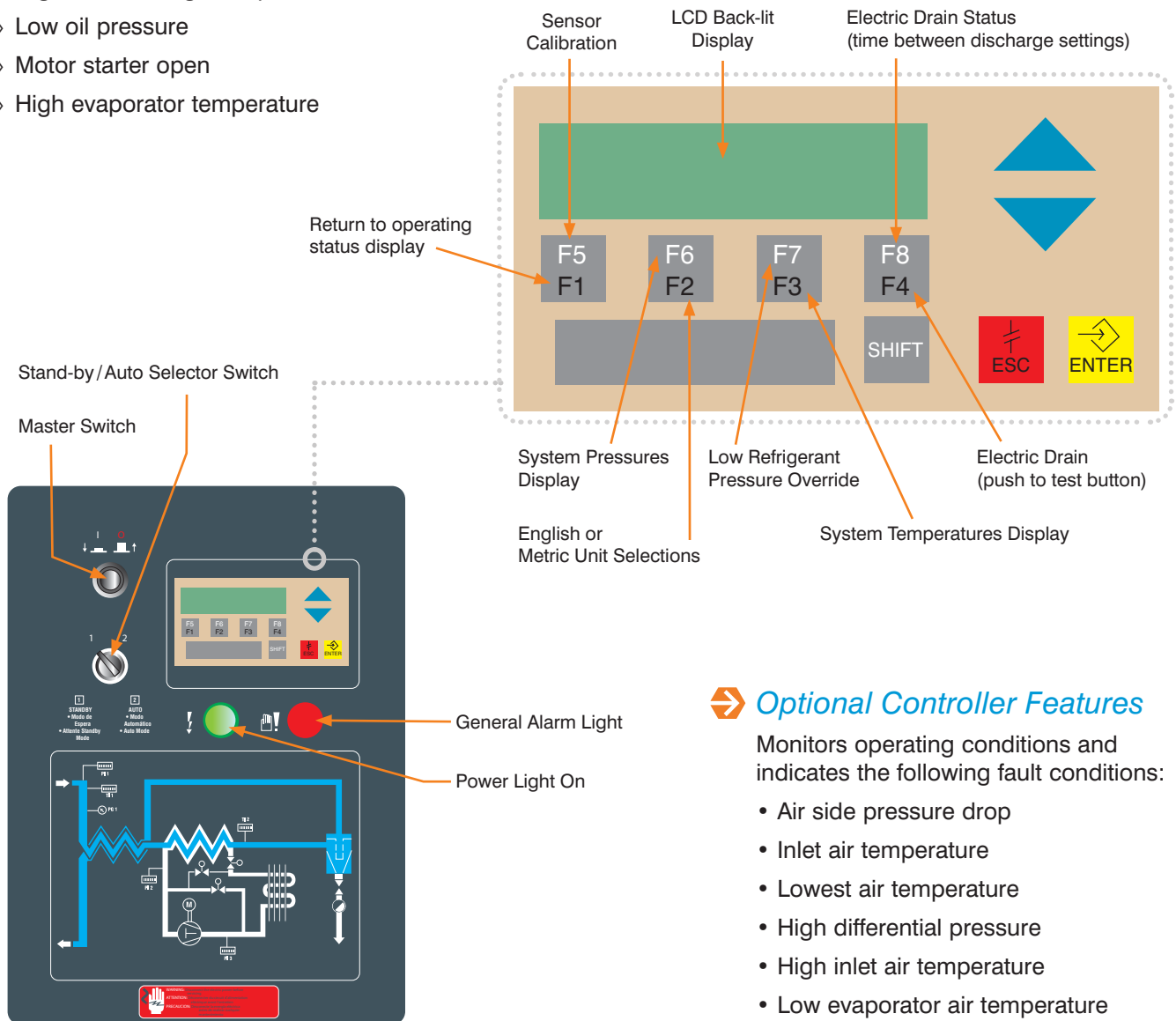

## ➤ Optional Controller Features

Monitors operating conditions and indicates the following fault conditions:

- Air side pressure drop
- Inlet air temperature
- Lowest air temperature
- High differential pressure
- High inlet air temperature
- Low evaporator air temperature
- Low water pressure (water-cooled models only)
- High condensate level

# Specifications



## Product Specifications

Model	Flow Capacity (SCFM) (1)	Refrigeration Compressor Nominal Horsepower				Maximum Working Pressure (MWP)
		Water-Cooled Models		Air-Cooled Models		
		38°F Pressure Dew Point	50°F Pressure Dew Point	38°F Pressure Dew Point	50°F Pressure Dew Point	
CHC0011	2000	10	7.5	10	7.5	175 psig (12 bar) Standard, high pressures available
CHC0012	2250	10	7.5	10	7.5	
CHC0022	2500	10	7.5	15	7.5	
CHC0033	3000	15	10	15	10	
CHC0034	3500	15	10	20	15	
CHC0044	4000	20	10	25	15	
CHC0045	4500	25	15	25	15	
CHC0055	5000	25	15	30	20	
CHC0066	6000	30	20	35	25	
CHC0067	7000	35	25	35	25	
CHC0077	8000	35	25	40	30	
CHC0078	8500	40	30	50	35	
CHC0088	10000	40	35	50	35	
CHC0099	12000	60	35	70	40	
CHC1010	15000	70	50	70	50	
CHC1111	20000	80	70	80	70	

1. Rated Flow Capacity - Conditions for rating dryers are in accordance with CAGI (Compressed Air and Gas Institute). Standard ADF100: Refrigerated Compressed Air Dryers - Methods for Testing and Rating: Conditions for rating above dryers are: 100 psig and 100°F saturated inlet air, 85°F cooling water (water-cooled models) 100°F ambient air (air-cooled models) and a maximum 5 psi pressure drop. Actual dew point may vary from the stated nominal value depending on site conditions and operating parameters. Flow capacities vary with operating conditions. For non-rated conditions contact factory to determine correct dryer size.



### *Dimensions, Connections, Weights*

Model	Flow Capacity (SCFM)	In/Out Connections ANSI Flg	Dimensions H x W x D (in)	Weight (lbs)
CHC0011	2000	4"	80 x 113 x 54	3177
CHC0012	2250	4"	80 x 113 x 54	3390
CHC0022	2500	4"	80 x 113 x 54	3443
CHC0033	3000	6"	81 x 113 x 54	3874
CHC0034	3500	6"	83 x 113 x 54	3984
CHC0044	4000	6"	84 x 113 x 54	4309
CHC0045	4500	6"	84 x 113 x 54	4674
CHC0055	5000	8"	87 x 113 x 54	4963
CHC0066	6000	8"	93 x 128 x 60	6012
CHC0067	7000	8"	93 x 128 x 60	6691
CHC0077	8000	10"	97 x 128 x 60	7318
CHC0078	8500	10"	97 x 156 x 78	7911
CHC0088	10000	10"	100 x 156 x 78	9924
CHC0099	12000	10"	101 x 156 x 78	10915
CHC1010	15000	12"	119 x 160 x 86	11640
CHC1111	20000	14"	112 x 194 x 96	19000

# Aftermarket Parts & Lubricants

## *Protect the Investment in CompAir*

Regular maintenance and service of CompAir product is critical to the performance and longevity of the equipment. Only CompAir can provide the assurance that the investment will provide a lifetime of productivity.

## *Reliability*

Only CompAir can provide aftermarket parts and services that are engineered for use in CompAir products. The parts and lubricant have been tested under rigorous conditions at the factory to the highest quality standards.

## *Performance*

Only CompAir can provide aftermarket parts designed specifically for the CompAir product. Use of OEM parts ensures that the investment in CompAir will continue to perform year in and year out with the same reliability and efficiency.

## *Ease of Doing Business*

Only CompAir can provide the peace of mind of turning to one supplier and one source for all aftermarket needs. CompAir has the support network in place to handle all customer service, service and technical support needs.

## *Value*

Only CompAir can provide the high quality aftermarket parts and services for the life of the investment in CompAir. Proper care of the CompAir product is vital to the equipment's performance and efficiency. Lean on a trusted source—CompAir.



[www.CompAir.com](http://www.CompAir.com) [sales@CompAir.com](mailto:sales@CompAir.com)

CompAir USA  
1301 North Euclid Avenue  
Princeton, IL 61356  
United States of America  
Tel (866) 994-8807  
Fax (800) 443-7790

CompAir Canada  
871 Cranberry Court  
Oakville, Ontario L6L 6J7  
Canada  
Tel (905) 847-0688  
Fax (905) 847-8124



Please recycle after use.

©2011 Gardner Denver, Inc.  
CU-AT-CHC 1st Ed. 6/11

Printed in U.S.A.

Member

